

(Model.)

2 Sheets—Sheet 1.

J. M. PALMER. CHUCK JAW.

No. 368,965.

Patented Aug. 30, 1887.

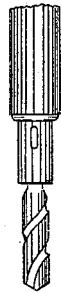
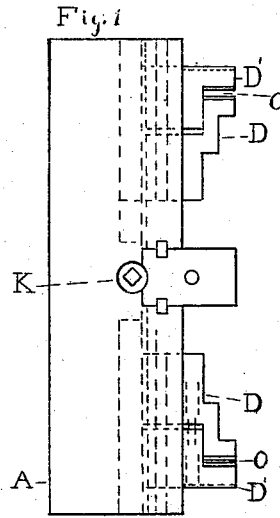
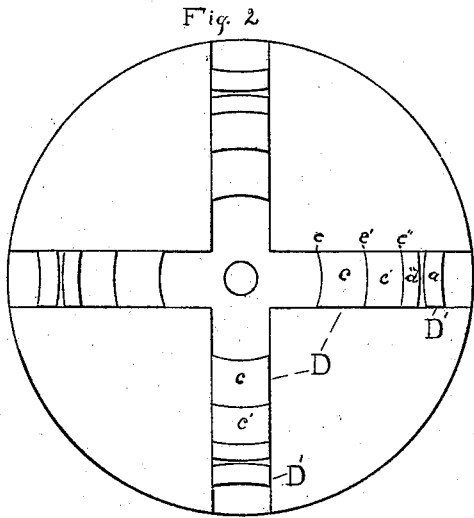
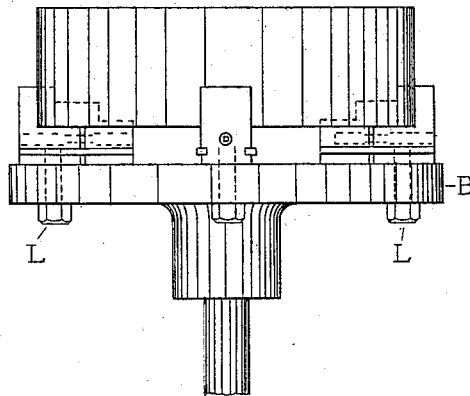

Fig. 3



WITNESSES:

H. J. Bingham
Emma F. Elmore

INVENTOR

John M. Palmer
BY *Jas. F. Williamson*

ATTORNEY

J. M. PALMER

CHUCK JAW.

No. 368,965.

Patented Aug. 30, 1887.

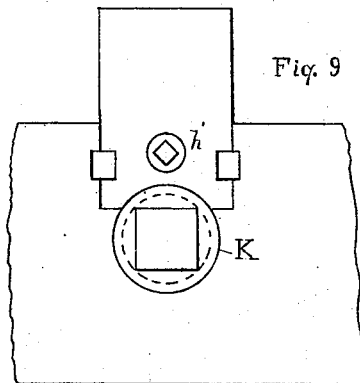
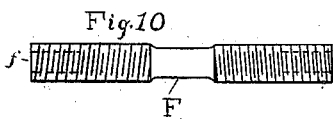
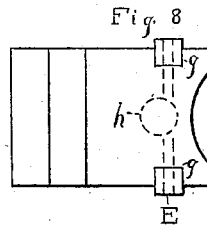
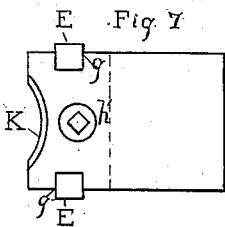
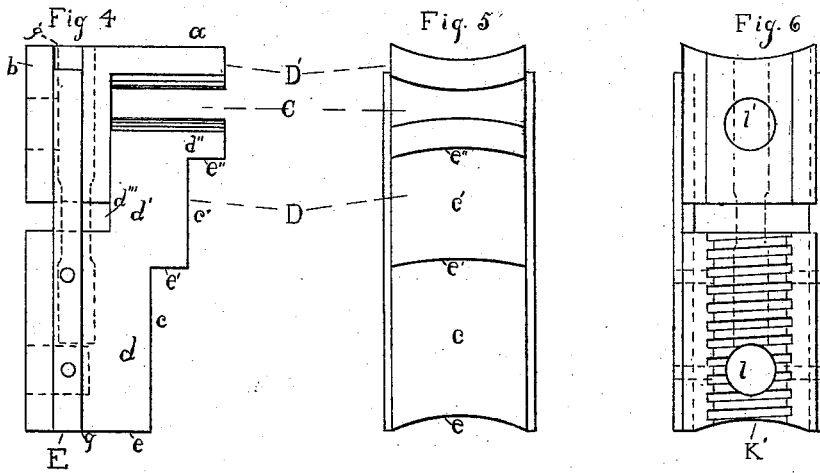

WITNESSES:

H. J. Bingham
Emma F. Elmore

INVENTOR

John M. Palmer
 BY *Geo. P. Williamson*
 ATTORNEY

UNITED STATES PATENT OFFICE.

JOHN M. PALMER, OF ST. PAUL, MINNESOTA.

CHUCK-JAW.

SPECIFICATION forming part of Letters Patent No. 368,965, dated August 30, 1887.

Application filed April 18, 1887. Serial No. 235,295. (Model.)

To all whom it may concern:

Be it known that I, JOHN M. PALMER, a citizen of the United States, and a resident of the city of St. Paul, county of Ramsey, State of Minnesota, have invented a certain new and useful Improvement in Chuck-Jaws, of which the following is a specification, reference being had to the accompanying drawings.

10 My invention relates to chuck-jaws designed for lathe-chucks, drill-press plates, and similar machines; and it has for its object to overcome defects in existing mechanism and to provide a jaw of superior efficiency and capable of a
15 greater variety of uses.

The jaws now in general use hold the pulley or other article to be operated upon by pressure inward or outward on a single side. As, for example, in the case of a pulley the faces
20 of the jaws are applied opposite each other either to the interior or exterior of the rim, and are pressed apart or toward each other tight enough to hold the pulley in position. This frequently results in the breakage, strain,
25 or distortion of the wheel or pulley. By my invention I overcome this defect by clamping the rim between two opposing faces of the jaw and rendering the pressure inside and outside exactly the same.

30 My invention consists in the construction hereinafter fully described, and particularly set out in the claims.

In the drawings, like letters referring to like parts throughout, Figure 1 is a side elevation
35 of a lathe-chuck with my improved jaw in position. Fig. 2 is a plan view of the same. Fig. 3 is a side elevation of my jaw as applied to a drill-press plate. Figs. 4 to 10, inclusive,
40 are detached views, said Fig. 4 being a side elevation of the jaw; Fig. 5, a face view of the same; Fig. 6, a back view; Fig. 7, a view from the outer end, and Fig. 8 a view from the inner end, said Fig. 9 being a side elevation on
45 an enlarged scale of a part of a chuck, showing an outer end view of the jaws in position, and said Fig. 10 showing the screw for operating the movable parts of the jaw.

A represents a lathe-chuck, and B a drill-press plate of the ordinary form. The chuck
50 A is provided with radial slots in the ordinary manner.

C is the chuck-jaw taken as a whole.

D D' are the opposing or complementary parts of the same, of which D is the inner, and D' the outer, of the two opposing jaws. 55

d d' d'' is the body of the inner jaw, which is shouldered or cut away on its upper face into a series of steps, e e', so that there is presented an inner series of gripping-faces, e' e''. The body of the inner jaw, D, is also cut away
60 on the outer part of its under side, as shown at d'', and the part d is provided on its opposite sides with the longitudinal grooves g, in which are rigidly secured the gibs E, projecting outward beyond the face of the jaw. The
65 part d is also provided with the central longitudinal screw-threaded hole, h.

The outer jaw, D', consists of the base or body b and the upright or vertical portion a. The base b is provided on its opposite sides
70 with longitudinal grooves g' and with a central longitudinal screw-threaded hole, h'. When the parts are in working position, the holes h h' and the grooves g g' coincide, the gibs E resting in said grooves and serving as guides
75 for the movable jaw.

In the screw-threaded holes h and h' is placed the operating-bolt F, which is provided with right and left handed male screw-threads on its opposite extremities for engaging corre-
80 sponding right and left female screw-threads in the jaws. The operating-bolt F is provided with a rectangular recess, f, in its outer extremity for the application of a wrench. The
85 outer face of the jaw D' and all the inner gripping-faces of the jaw D are concave in cross-section, while the inner face of D' and the outer face of D are convex in shape. The backs of
90 both jaws are concave, and the part d is provided on its back with a screw-thread, K', for engaging with the ordinary screw, K, placed below the radial slot in the lathe-chuck for moving the chuck-jaw as a whole back and forth toward or from the center of the chuck.

The backs of both jaws are provided with
95 vertical screw-threaded holes l l', into which fit screw-threaded bolts L when the chuck-jaw is applied to a drill-press plate, as shown in Fig. 3. Either the outer or the inner jaw may thus be rigidly connected to the face of
100 the plate, and the other jaw be moved at will by the operating-bolt F.

The operation of my invention is clear from the description already given. When used on

a lathe-chuck, it is placed with its back or base resting in the radial slots, and the outer jaws are fixed at the proper distances from the center by the screw K. The pulley or wheel is then placed in position on the top face of the base of the outer jaw, D', and by the bolt F the two convex vertical faces of the jaws are drawn toward each other and made to grip the rim of the wheel or pulley with exactly equal pressure from each side. All possibility of strain or distortion is thereby prevented.

It is evident that my jaw is also capable of being used exactly as the jaws in common use, the faces *e*, *e'*, and *e''* being used for the purpose; or in case a higher opposing surface is desired, or in case it is necessary to hold a very small article, the device may be turned end for end and the outer face of the jaw D' be used. In the case of large wheels, which it is desirable to clamp between the opposing convex faces of the jaws D and D', the device may also be turned end for end, and the body *d d'* be allowed to project outward beyond the periphery of the chuck.

It is evident that my improvement may be readily applied to the common chuck-jaw by making the necessary and easily-made changes in the same, and adding the outer jaw, the gibs, and the operating-bolt.

What I claim, and desire to secure by Letters Patent of the United States, is as follows:

1. A chuck-jaw consisting of a pair of movable opposing gripping-jaws, and suitable mechanism for drawing together or separating said jaws, whereby a pulley or similar article may be clamped to a chuck with equality of pressure on the interior and exterior of its rim and all strain is prevented.

2. In combination, the jaws D and D', pro-

vided with coincident screw-threaded holes *h* and *h'*, and the operating right and left screw-threaded bolt F, as and for the purpose set forth.

3. In combination, the jaws D and D', provided with the coincident grooves *g* and *g'* and the gibs E, and means for drawing together or separating said jaws.

4. In combination, the jaw D, cut away, as at *d'''*, and provided with screw-threaded hole *h* and the grooves *g*, the jaw D', having the base *b*, extended at right angles and adapted to fit into the space formed by cutting away the jaw D, and provided with the screw-threaded hole *h'* and the grooves *g'*, the gibs E, and the operating right and left screw-threaded bolt F, as and for the purpose set forth.

5. The chuck-jaw C, as described, consisting of the inner jaw, D, shaped as set forth, having a convex gripping-surface on its outer vertical face and concave gripping-surfaces on its inner vertical faces, *e e' e''*, and provided with the screw-threaded hole *h*, the gib-grooves *g*, the vertical screw-threaded hole *l*, and the screw-thread K', the outer jaw, D', shaped as set forth, having a convex gripping-surface on its inner vertical face and a concave gripping-surface on its outer vertical face, and provided with the screw-threaded holes *h* and *h'*, and the gib-grooves *g'*, the gibs E, and the operating-bolt F, provided with the rectangular wrench-head recess *f*, substantially as and for the purpose set forth.

JOHN M. PALMER.

In presence of—

J. F. WILLIAMSON,
EMMA F. ELMORE.